



3500 Pelco Way,
Clovis, CA 93612-5699
USA

In North America & Canada:
Tel (800) 289-9100
FAX (800) 289-9150

International Customers:
Tel +1 (559) 292-1981
FAX +1 (559) 348-1120

www.pelco.com

C1467M-A (3/00) EH2200 Indoor Enclosure

IMPORTANT SAFEGUARDS AND WARNINGS

Prior to installation and use of this product, the following WARNINGS should be observed.

1. Installation and servicing should only be done by qualified service personnel and conform to all local codes.
2. Unless the unit is specifically marked as a NEMA Type 3, 3R, 3S, 4, 4X, 6 or 6P enclosure, it is designed for indoor use only and it must not be installed where exposed to rain and moisture.
3. Only use replacement parts recommended by Pelco.
4. The installation method and materials should be capable of supporting four times the weight of the enclosure, camera and lens combination.

The product and/or manual may bear the following marks:



This symbol indicates that dangerous voltage constituting a risk of electric shock is present within this unit.



This symbol indicates that there are important operating and maintenance instructions in the literature accompanying this unit.

CAUTION:

RISK OF ELECTRIC SHOCK. DO NOT OPEN.

Please thoroughly familiarize yourself with the information in this manual prior to installation and operation.

DESCRIPTION

The EH2200 is a medium security enclosure that mounts to the corner of two walls. It can be installed flush against the ceiling or mid-wall in high ceiling applications. The enclosure's compact design is perfect for small cameras. Total camera and lens length must not exceed 5 inches (12.70 cm).

INSTALLATION

The following items are supplied:

- 1 5/32-inch hex key
- 1 Camera mounting screw, 1/4-20 x .375-inch, Phillips, pan head

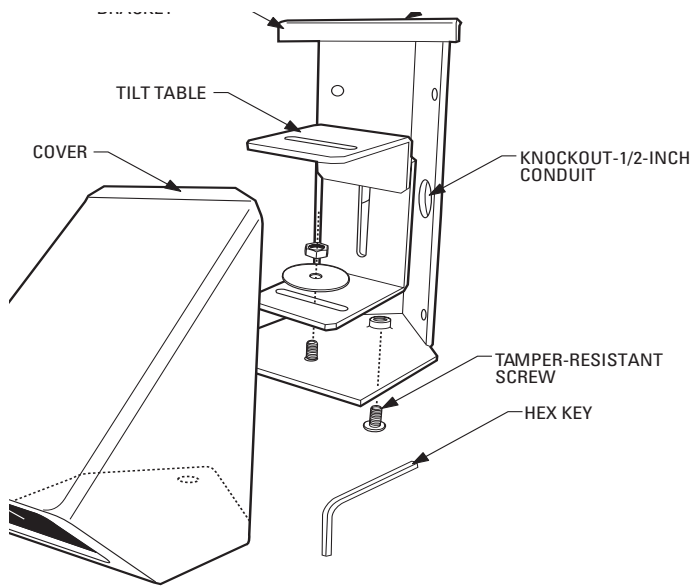
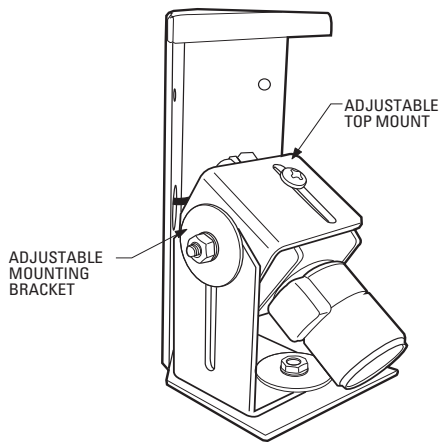

Figure 1. EH2200 Exploded Assembly



Camera and lens mounting position can vary. Illustration shows top of camera mounted to the tilt table. Bottom of camera also can be mounted to the tilt table.

Figure 2. Camera Mounting

To install the EH2200 refer to Figure 1 and do the following:

1. Ensure that the mounting surface is capable of supporting four times the weight of the enclosure, camera and lens.
2. Remove the cover by loosening the tamper-resistant screw with the enclosed hex key.
3. Remove the tilt table assembly.
4. Determine the mounting location. Use the mounting bracket as a template and mark the four fastener positions onto the mounting surface.
5. Remove the appropriate knockouts needed for camera power and video wiring. Pull wiring into the enclosure.
6. Fasten the mounting bracket to the surface. Secure with a recommended minimum of 1/4-20 screws (not supplied).
7. Reinstall the tilt table assembly.
8. Mount the camera and lens to the top or bottom of the tilt table with the 1/4-20 x .375-inch screw. Extend the lens to its maximum length before installing. This will ensure that the lens has enough clearance and will not hit the window during focusing. Refer to Figure 2.
9. Replace the enclosure cover. Check that all components clear the cover and that the camera angle and lens adjustments are satisfactory. When all adjustments are complete, secure the cover.

MAINTENANCE

Clean the window regularly to help maintain picture clarity. Use a soft cloth and a mild nonabrasive detergent. To order replacement parts, refer to Table A.

Table A. Mechanical Parts List

Qty	Description	Part Number
1	Mounting bracket weld assembly	EH22001001WA
1	Cover weld assembly	EH22001000WA
1	Window	EH220010000
1	Button head tamper-proof screw	ZH8-32X.500TSS
2	4-40 hex nut	ZH4-40NUTSH
2	Flat washer	ZH125X312X32S
1	Tilt table support leg	EH22004003COMP
1	Tilt table	EH22004004COMP
2	1/4-20 hex nut	ZH1/4-20NUTCH
2	.25-inch split lock washer	ZH1/4LWSSL
2	Fender washer	ZH255X1.50X62

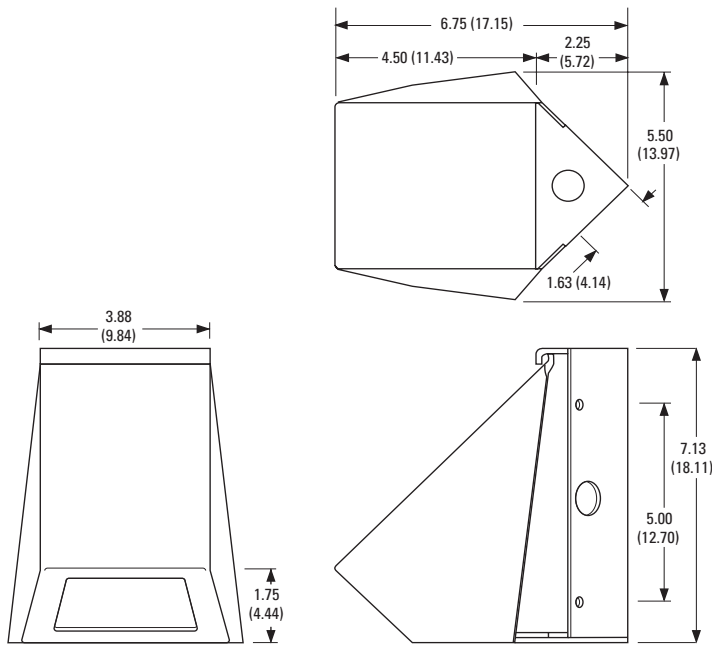

NOTE: VALUES IN PARENTHESES ARE CENTIMETERS;
ALL OTHERS ARE IN INCHES.

Figure 3. EH2200 Dimension Drawing

SPECIFICATIONS

MECHANICAL

Camera Mounting: Adjustable tilt table

Maximum Camera/Lens Size: Accommodates camera/lens combinations (including BNC connector) up to: 5.0 (L) x 4.0 (W) x 4.0 (H) inches (12.7 x 10.16 x 10.16 cm)

Viewing Window: .187-inch (4.76 mm) thick LEXAN®

Window Viewing Area: 3.00 (W) x 1.88 (H) inches (7.62 x 4.78 cm)

Cable Entry Holes: .875-inch diameter access through rear walls and top

Enclosure Mounting: Four .25-inch diameter holes on protected rear surfaces

GENERAL

Construction: .125-inch (3.175 mm) thick aluminum

Finish: Gray polyester powder coat

Dimensions: See Figure 3

Environment: Indoor

Unit Weight: 2.0 lb (0.91 kg)

PRODUCT WARRANTY AND RETURN INFORMATION

WARRANTY

Pelco will repair or replace, without charge, any merchandise proved defective in material or workmanship **for a period of one year** after the date of shipment.

Exceptions to this warranty are as noted below:

- Five years on FT/FR8000 Series fiber optic products.
- Three years on Genex® Series products (multiplexers, server, and keyboard).
- Three years on Camclosure® and fixed camera models, except the CC3701H-2, CC3701H-2X, CC3751H-2, CC3651H-2X, MC3651H-2, and MC3651H-2X camera models, which have a five-year warranty.
- Two years on standard motorized or fixed focal length lenses.
- Two years on Legacy®, CM6700/CM6800/CM9700 Series matrix, and DF5/DF8 Series fixed dome products.
- Two years on Spectra®, Esprit®, ExSite™, and PS20 scanners, including when used in continuous motion applications.
- Two years on Esprit® and WW5700 Series window wiper (excluding wiper blades).
- Eighteen months on DX Series digital video recorders, NVR300 Series network video recorders, and Endura™ Series distributed network-based video products.
- One year (except video heads) on video cassette recorders (VCRs). Video heads will be covered for a period of six months.
- Six months on all pan and tilts, scanners or preset lenses used in continuous motion applications (that is, preset scan, tour and auto scan modes).

Pelco will warrant all replacement parts and repairs for 90 days from the date of Pelco shipment. All goods requiring warranty repair shall be sent freight prepaid to Pelco, Clovis, California. Repairs made necessary by reason of misuse, alteration, normal wear, or accident are not covered under this warranty.

Pelco assumes no risk and shall be subject to no liability for damages or loss resulting from the specific use or application made of the Products. Pelco's liability for any claim, whether based on breach of contract, negligence, infringement of any rights of any party or product liability, relating to the Products shall not exceed the price paid by the Dealer to Pelco for such Products. In no event will Pelco be liable for any special, incidental or consequential damages (including loss of use, loss of profit and claims of third parties) however caused, whether by the negligence of Pelco or otherwise.

The above warranty provides the Dealer with specific legal rights. The Dealer may also have additional rights, which are subject to variation from state to state.

If a warranty repair is required, the Dealer must contact Pelco at (800) 289-9100 or (559) 292-1981 to obtain a Repair Authorization number (RA), and provide the following information:

1. Model and serial number
2. Date of shipment, P.O. number, Sales Order number, or Pelco invoice number
3. Details of the defect or problem

If there is a dispute regarding the warranty of a product which does not fall under the warranty conditions stated above, please include a written explanation with the product when returned.

Method of return shipment shall be the same or equal to the method by which the item was received by Pelco.

RETURNS

In order to expedite parts returned to the factory for repair or credit, please call the factory at (800) 289-9100 or (559) 292-1981 to obtain an authorization number (CA number if returned for credit, and RA number if returned for repair).

All merchandise returned for credit may be subject to a 20% restocking and refurbishing charge.

Goods returned for repair or credit should be clearly identified with the assigned CA or RA number and freight should be prepaid. Ship to the appropriate address below.

If you are located within the continental U.S., Alaska, Hawaii or Puerto Rico, send goods to:

Service Department
Pelco
3500 Pelco Way
Clovis, CA 93612-5699

If you are located outside the continental U.S., Alaska, Hawaii or Puerto Rico and are instructed to return goods to the USA, you may do one of the following:

If the goods are to be sent by a COURIER SERVICE, send the goods to:

Pelco
3500 Pelco Way
Clovis, CA 93612-5699 USA

If the goods are to be sent by a FREIGHT FORWARDER, send the goods to:

Pelco c/o Expeditors
473 Eccles Avenue
South San Francisco, CA 94080 USA
Phone: 650-737-1700
Fax: 650-737-0933

REVISION HISTORY

Manual #	Date	Comments
C1467M	7/97	Original version.
C1467M-A	3/00	Added instructions for mounting camera into the enclosure. Updated manual to new format.